

## INSTALLATION INSTRUCTIONS

Information below shall be treated as guidelines - the exact installation method may vary depending on the house construction. Please always follow work safety rules and good engineering practice.

### Installation of main connector for inlet/exhaust air.

#### Type 1: Central connector.

- 1 Turn the distribution box cover anticlockwise at the desired side and then take it off. Pay attention on which side of the distribution box the mounting holders are situated. Check if the seal is sitting at its place.
- 2 Prepare the central connector (sold separately) by cutting the stub end to the required dimension at indentation. For 125 mm pipe skip this step.

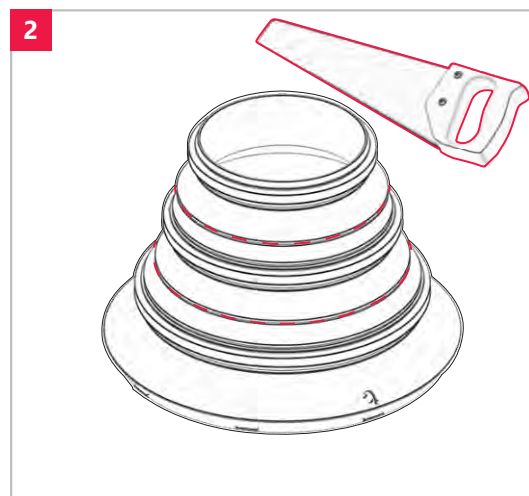
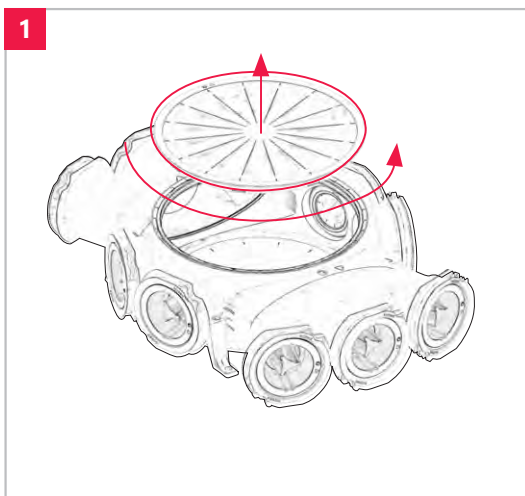

### Installation of main connector for inlet/exhaust air.

#### Type 2: side connector.

- 3 Place the top main connector inside the uncovered socket. Make sure that the connector entered the socket correctly and then turn the connector clockwise until the end.
- 1 Take off the 3x75 module from the distribution box by lifting the catches on both sides of the module using your fingers.

**Done!**

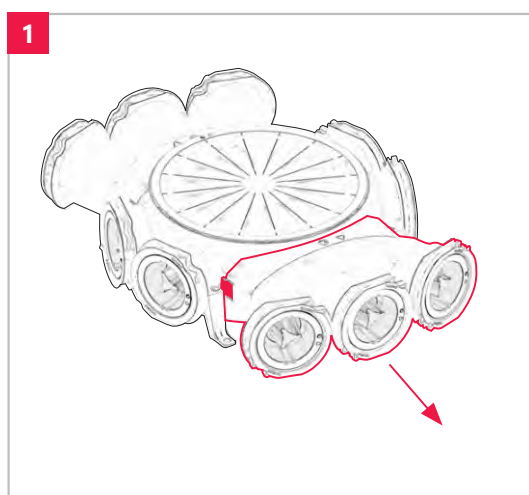
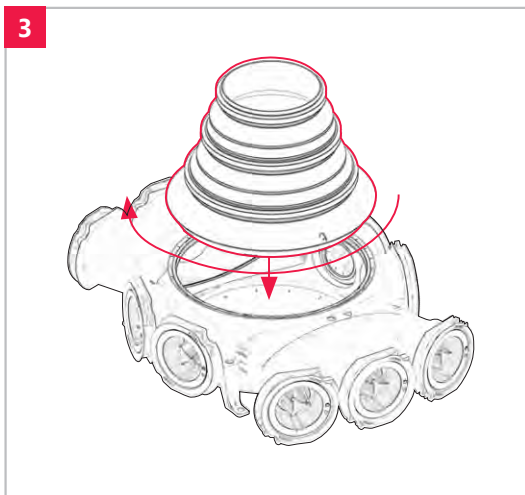

- 2 Prepare the side connector (sold separately) by cutting the stub end at indentation in order to connect 125 mm pipe. For 160 mm pipe cutting is not required.

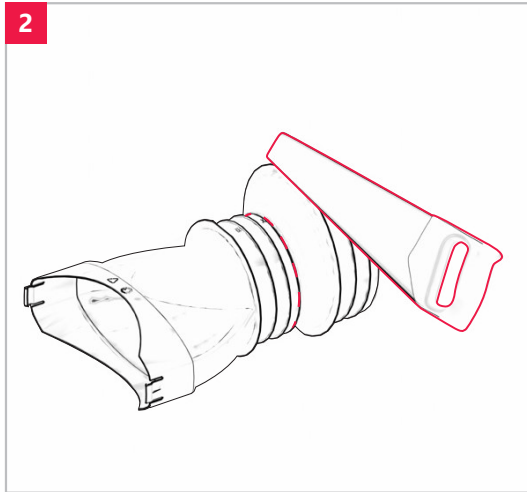

- 3 Make sure that the seal at the socket is properly placed, if not, correct it. If you notice that the seal is damaged, contact the distributor for a replacement.

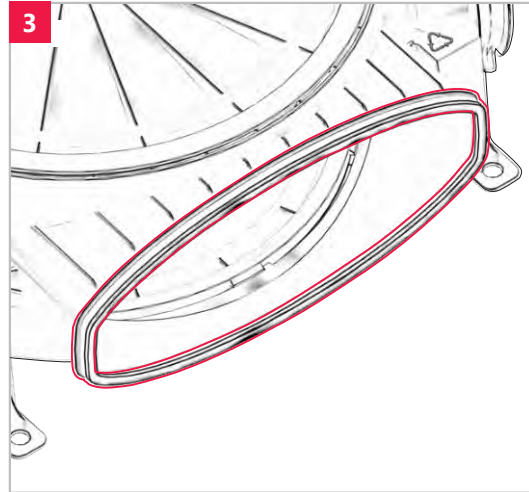

- 4 Slide the side connector on the uncovered elliptical slot. Check if the catches are properly fastened.

**Done!**

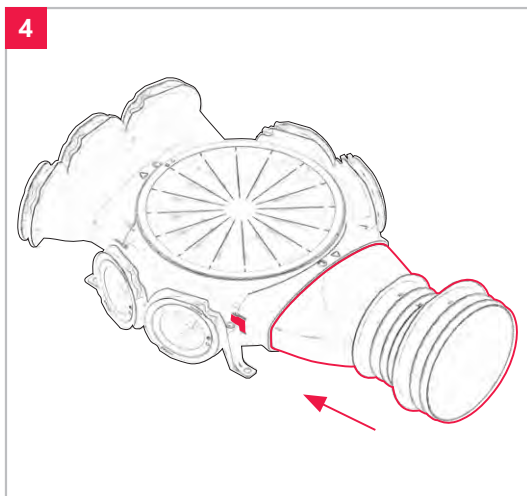

### Connection of main inlet/exhaust pipe to a distribution box

- 1 Connect the inlet or outlet air pipe from the HRV to the top or side connector. Regardless of pipe type, fix it to the connector. Air tightness is guaranteed by seals mounted on the connectors.

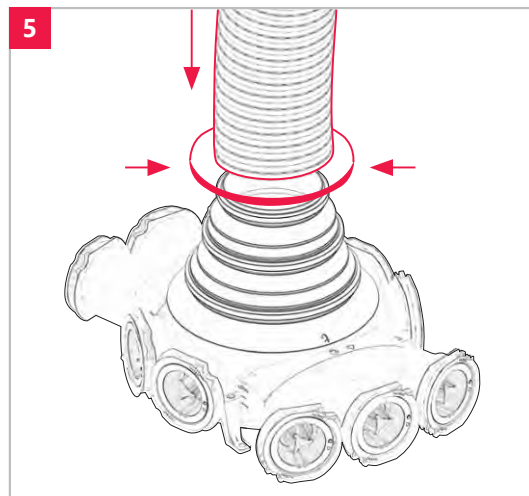

## CONNECTING DISTRIBUTION BOXES

Distribution boxes can be joined together horizontally or vertically using couplings when more than 10 sockets available in basic configuration are required.

### Type 1: Horizontal connection

- 1 Take off the 3x75 module from the distribution box by lifting the catches on both sides of the module using your fingers. Repeat on the second distribution box.
- 2 Make sure that the seal at the socket is properly placed, if not, correct it. If you notice that the seal is damaged, contact the distributor for a replacement.

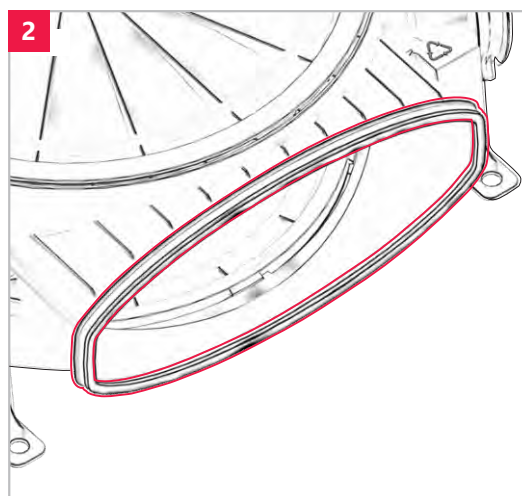
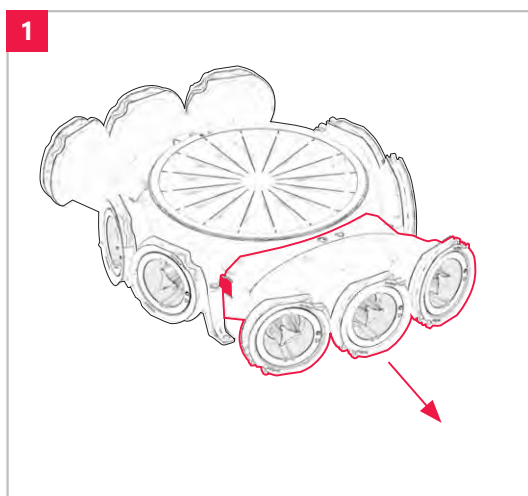

- 3 Slide the horizontal coupling on the elliptical slot of the first distribution box. Check if catches are properly fastened.
- 4 Slide the second distribution box into the horizontal connector **Done!** If needed, you can join more distribution boxes together.

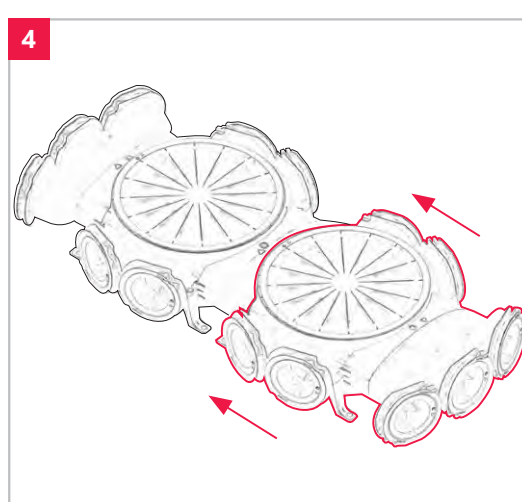
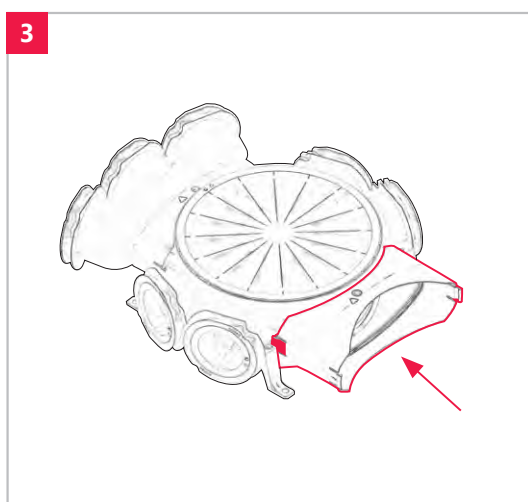

### Type 2: Vertical connection

- 1 Turn the distribution box cover anticlockwise at the desired side and then take it off. Pay attention to which side of the distribution box the mounting holders are situated. Check if the seal is sitting at its place. Repeat on the second distribution box.
- 2 Insert the vertical coupling into the uncovered socket of the bottom distribution box. Check if the coupling properly entered the socket and turn it clockwise until the end.

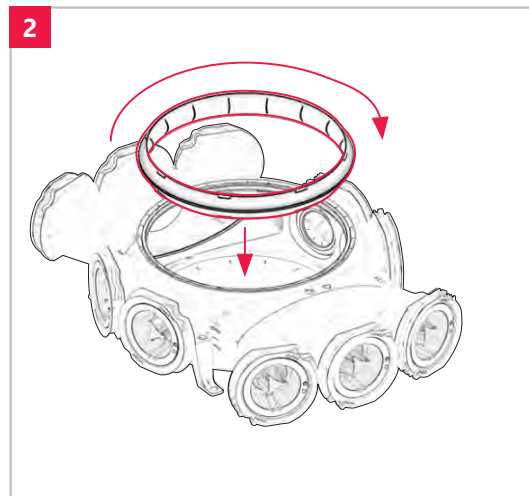
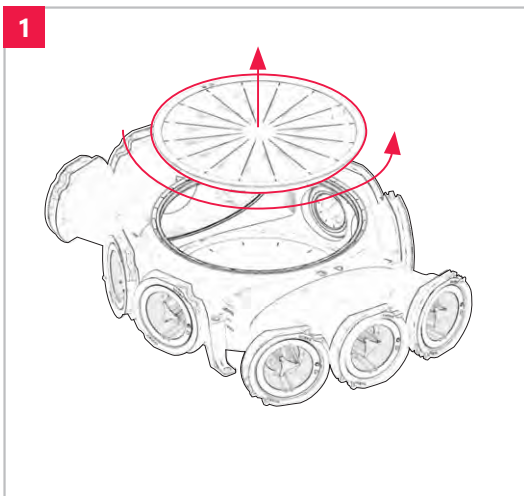

- 3 Place the second distribution box on top of the connector and turn it clockwise until the end.
- 4 **Done!** Depending on the needs, distribution boxes can be placed in any orientation to each other.

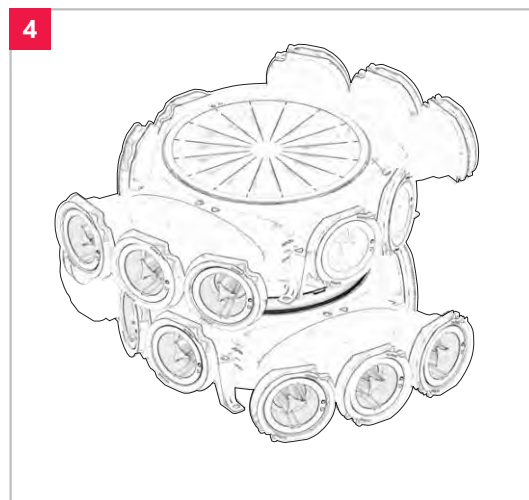
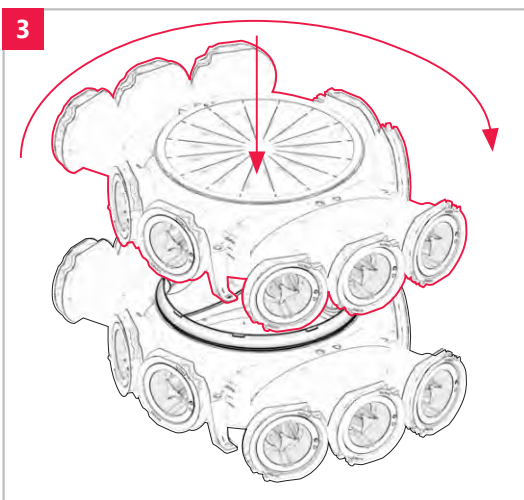

## PIPE INSTALLATION AND ROUTING

- 1 Cut the pipe to the desired length. The cut has to be perpendicular to the pipe surface, between pipe ridges. The cut has to be clean, without any jagged edges. Remove any shards that fell into the pipe.

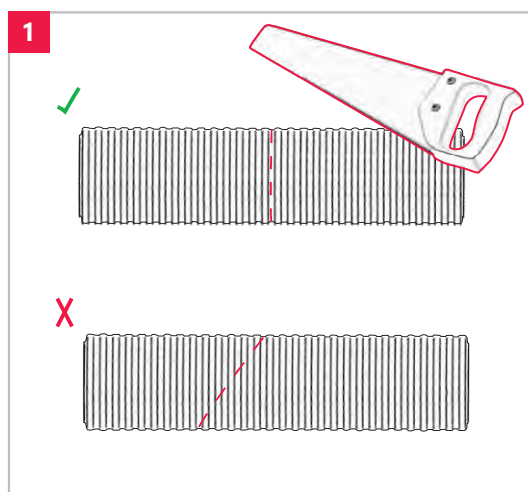

- 2 Turn the fastening ring into open position, pull out the end cap and then take the seal off the end cap. Turn the fastening ring back to the locked position.

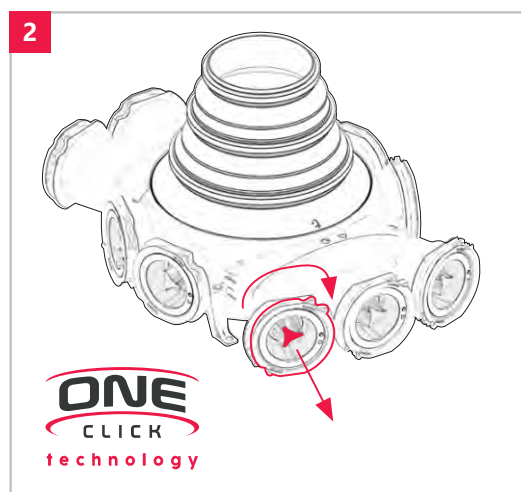

- 3 Place the seal on the first furrow of the pipe.

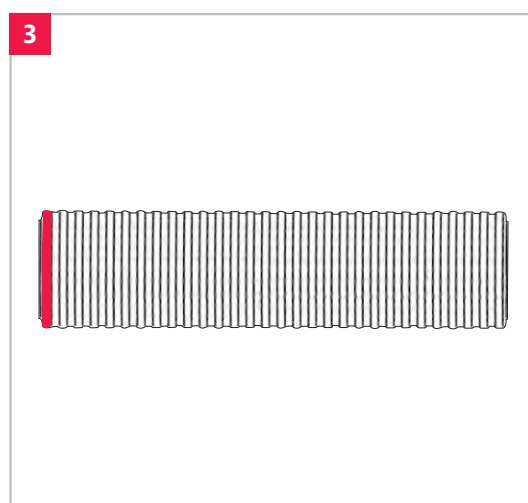

- 4 Slide the pipe into the empty distribution box socket.  
**ATTENTION:** The connection is air tight and does not require any additional sealing materials. Unused sockets must remain capped.

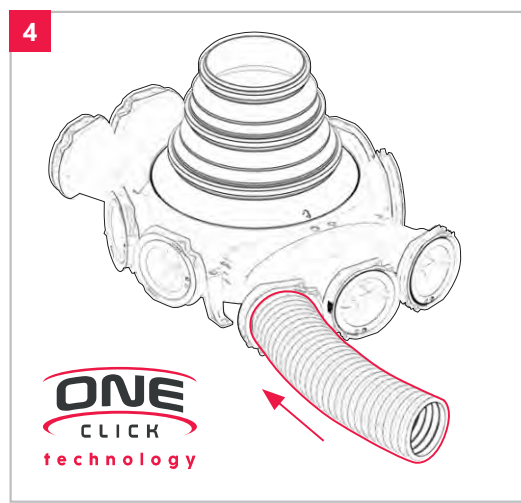

- 5 If there is a need to remove a pipe, turn the fastening ring into open position and remove the pipe.

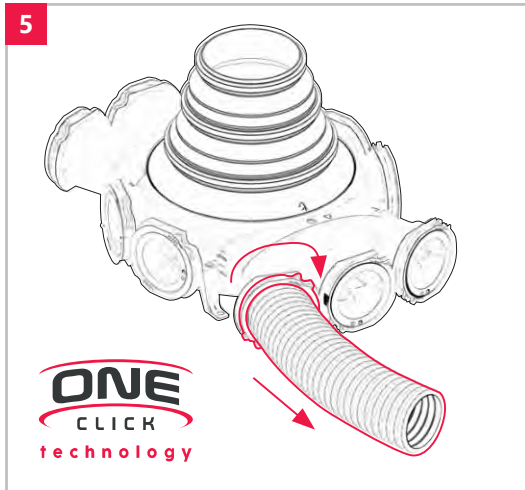

- 6 Keep the free pipe end capped during the construction works in order to keep the system clean of any debris.

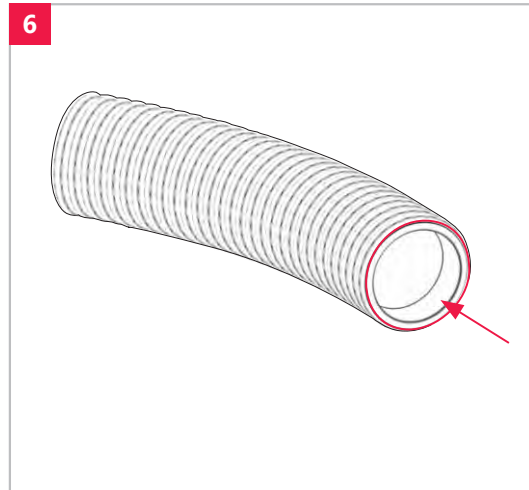

- 7 Fix the pipe to the surface by metal plumber's tape every 1-1.5 m and directly before and after pipe connector and next to the distribution and plenum boxes.

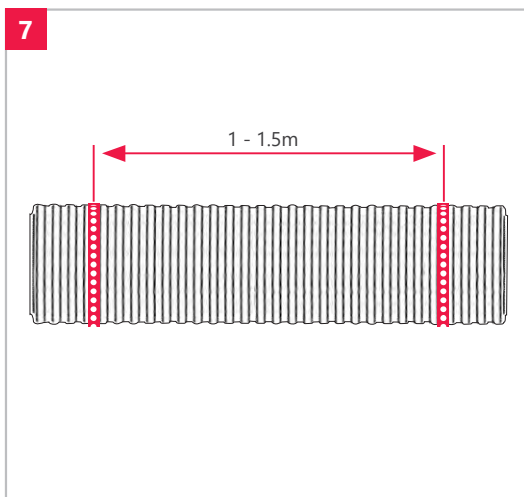



## PLENUM BOX

Plenum box is delivered in a factory assembled state. Plenum boxes are equipped with rotatable mounting wings allowing to install boxes both on a ceiling inside an insulation layer under the screed or inside a suspended ceiling.

- 1 Choose the place to install the plenum box. The box has to be situated minimum 350 mm from walls. The diameter of the hole has to be minimum 135 mm.

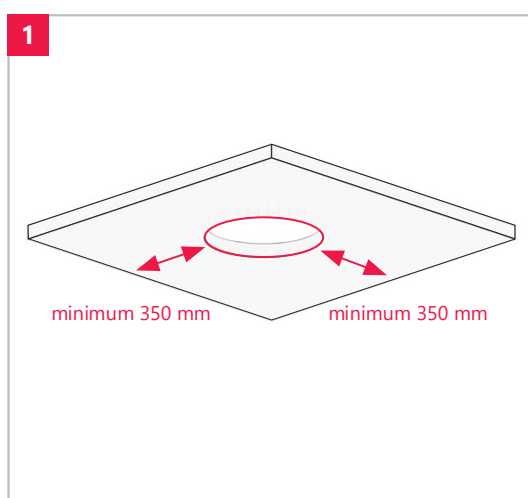

- 1, 3 Remove the regulation bolts and take out the mounting wings. Set them in the desired position, depending on the type of installation and the adjust the height by using regulation bolt. In case of installation on the ceiling, first make a hole through the ceiling.

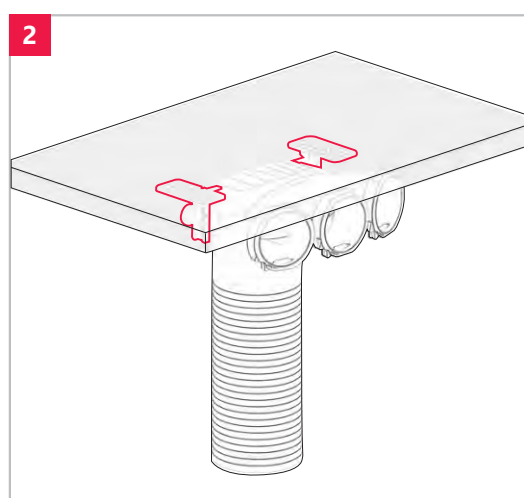

- 4 Fix the plenum box securely to the ceiling using the holes in the mounting wings by, for example, screws. Diameter of the wing holes is 5.3 mm.

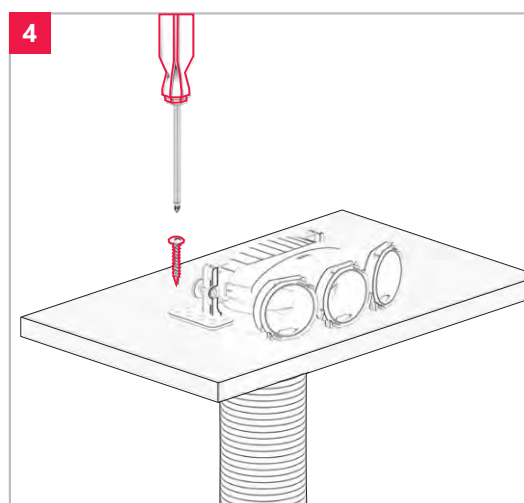
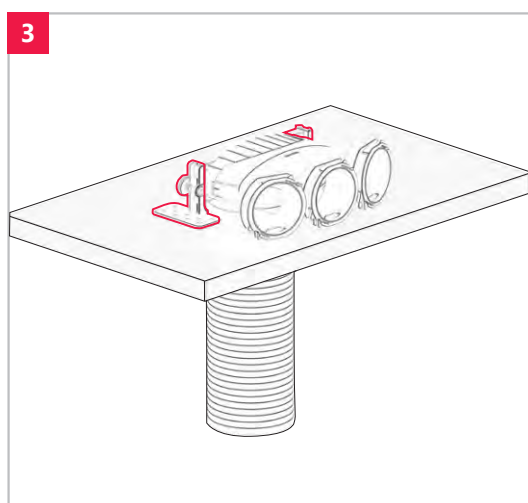

- 5 Take out the end cap from the socket, put the seal on the first furrow of the pipe and slide the pipe into the socket. Make sure that the fastening ring is in the locked position. When installing two pipes, use two outer sockets, one pipe - the middle socket. Unused sockets have to remain capped.

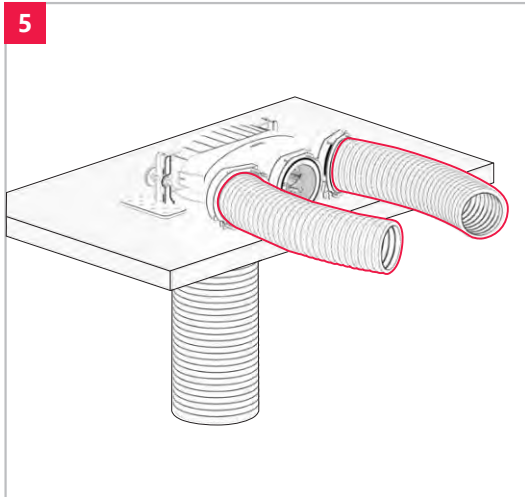

- 6 Cut the disc valve socket pipe of plenum box perpendicularly and on the same level as the ceiling surface. Place the endcap in the pipe for duration of construction works.

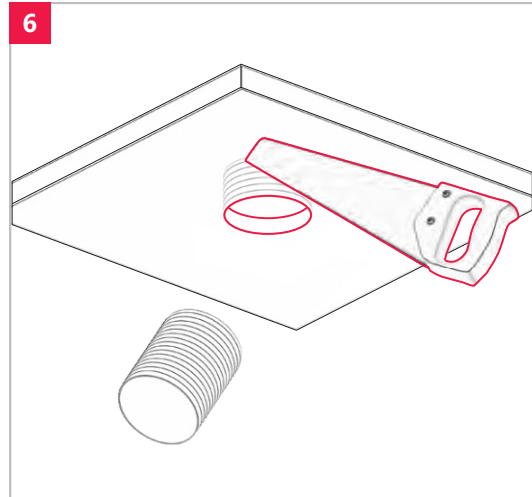

- 7 After construction works are finished place the disc valve inside the prepared pipe.

